

mitsui seiki



Five-axis control vertical machining center

Vertex 550-5X

Vertical machining center

Vertex 550



MITSUI SEIKI KOGYO CO., LTD.

Vertex

“Vertex” – It is a ve

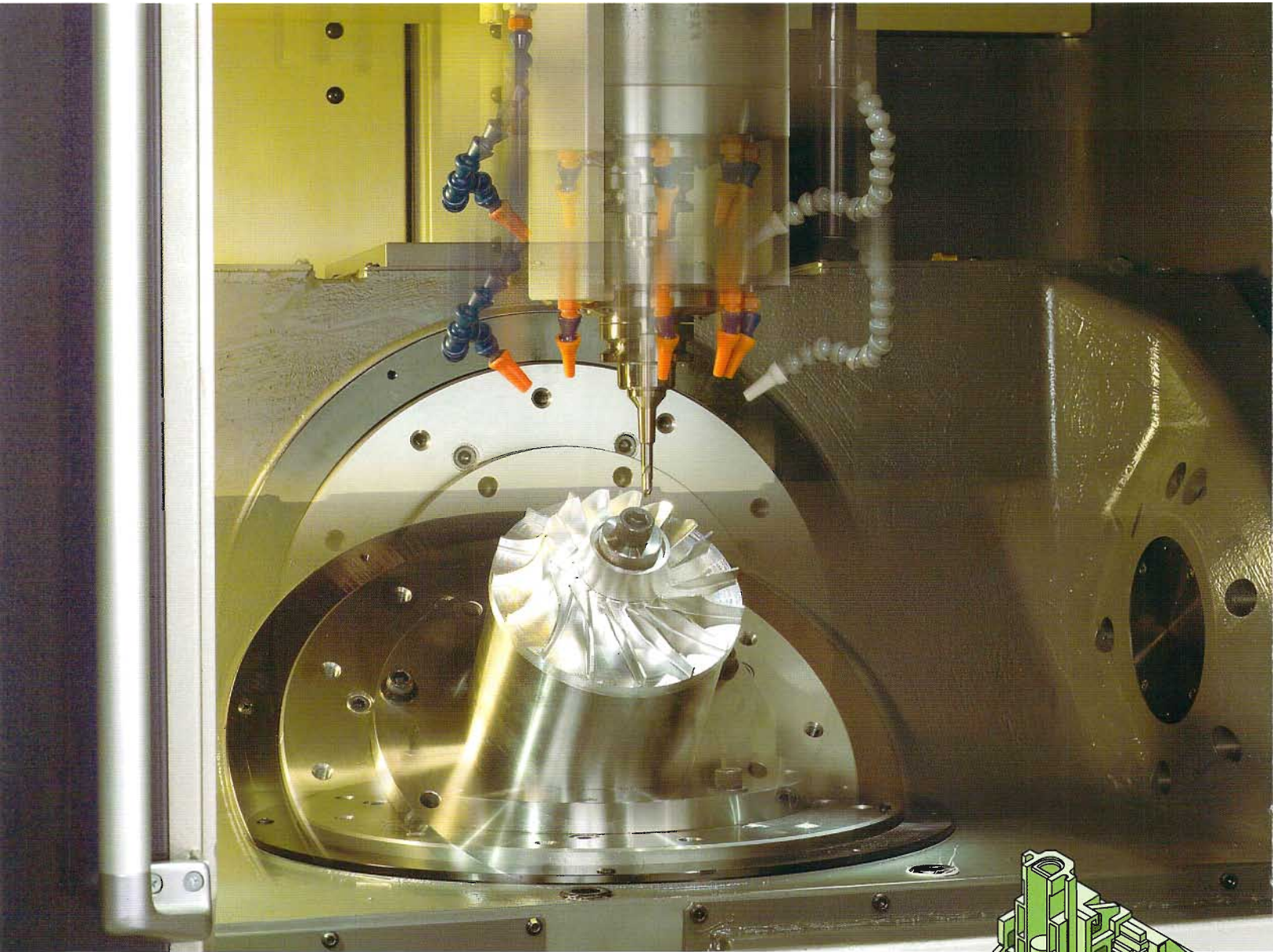

A vertical machining center with a new concept has been created by Mitsui Seiki, who as the top-level share in the horizontal trunnion type five-axis machining centers.

It's name is Vertex550/Vertex550-5X. “Vertex” has a meaning of “top” or “pinnacle”.

In its compact body, high-performance functions are concentrated. Especially, Vertex550-5X overturns the forbidding kind of image of five-axis machines and we made an effort so that it can be used as an extension of three-axis machines. Vertex makes five-axis machines even closer.

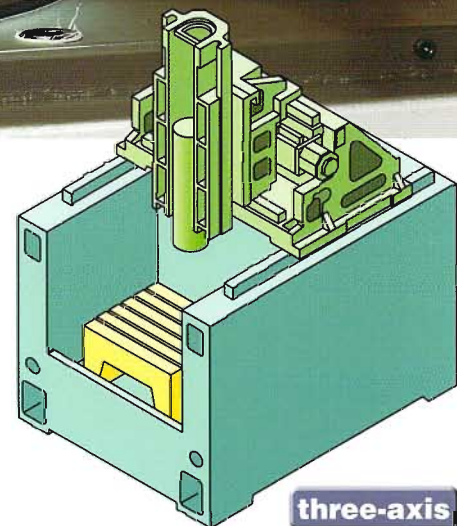

Vertical machining center that aims the “top”

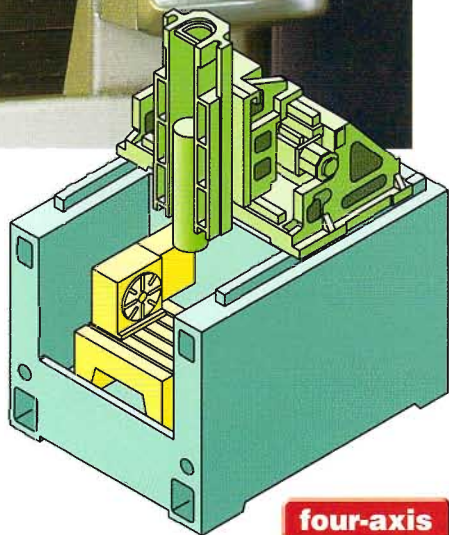
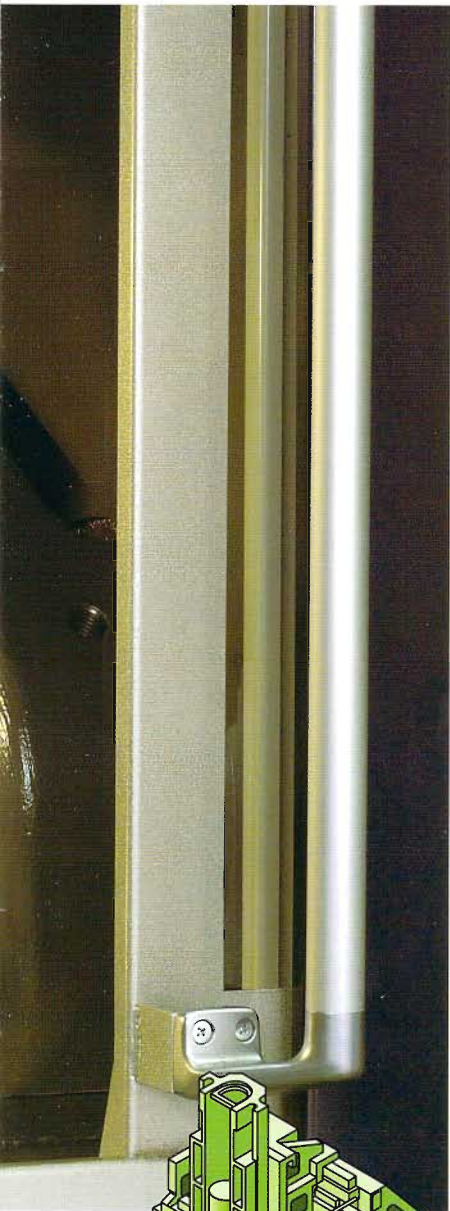

four-axis

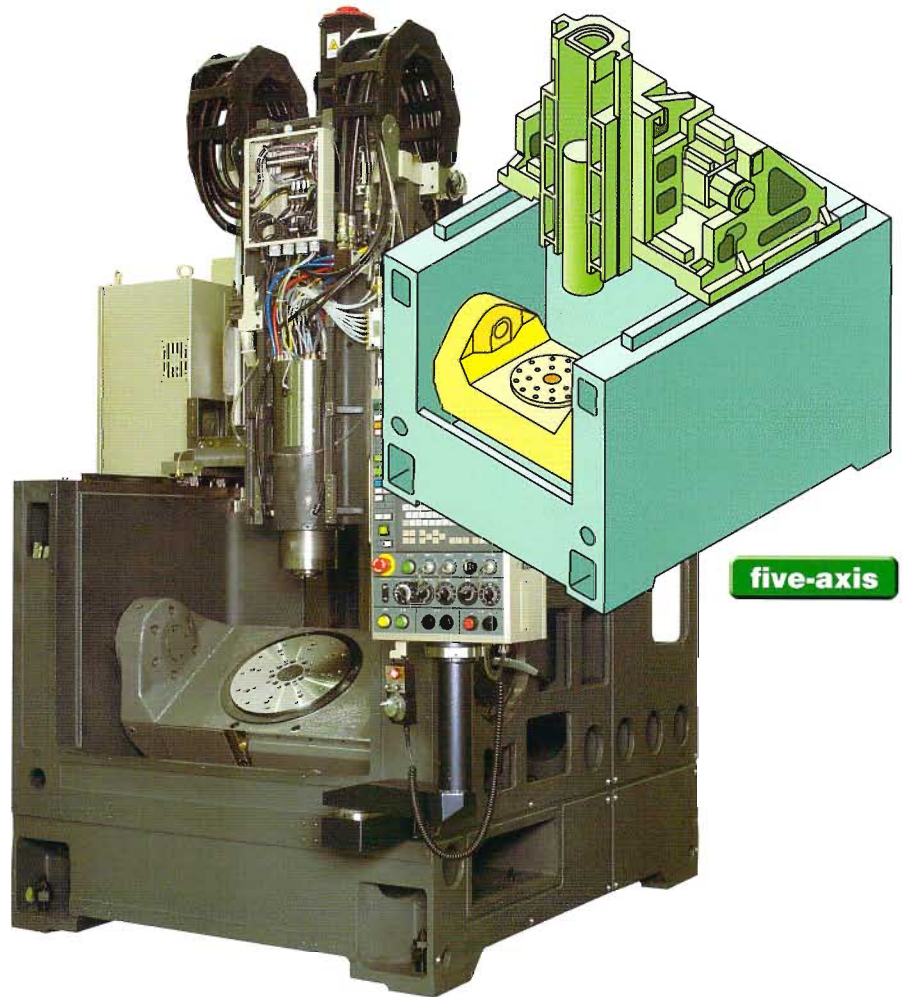

five-axis

The “Cube-on structure” Has realized various benefits that are unique to this machine.

We have adopted a structure where three axes of XYZ move on a high rigidity bed, which we have named the “cube on structure” for Vertex. This unique structure generates various features.

Small footprint

Three-axis, four-axis, and five-axis can be supported in a shared platform. In addition, the size of the workpieces supported by the five-axis specifications is virtually the same as that of three-axis specification, while the footprint is exactly the same.

Y-axis stroke best for five-axis processing

The ratio of the strokes of X-axis and Y-axis is about 1:1. This stroke ratio is best for five-axis processing. Y-axis stroke 600mm is the maximum size for a machine in this class, supporting processing of workpieces that cannot be processed by traditional compact machines

Furthermore, Vertex does not have the problem where the tip of the head goes slag when the Y-axis stroke is big in vertical machining center.

Excellent cutting chips handling

Cutting chips fall right under the table and discharged to outside of the machine immediately by the chip conveyer. Furthermore, the slanted A-axis of the five-axis specifications discharges almost all cutting chips on the workpieces.

Future expansibility

Expansibility utilizing the benefits of automation architecture and fixed table can be expected.

Smallest footprint with maximum processing

Five-axis control vertical machining center

Vertex 550-5X

Vertical machining center

Vertex 550



* The photo shows a special specification.

Vertex 550-5X

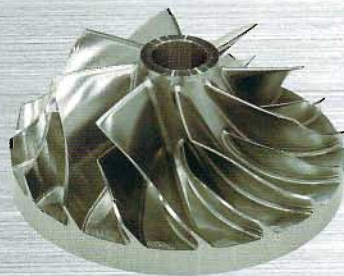
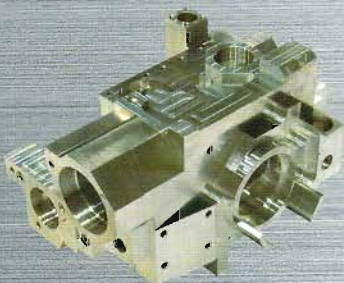

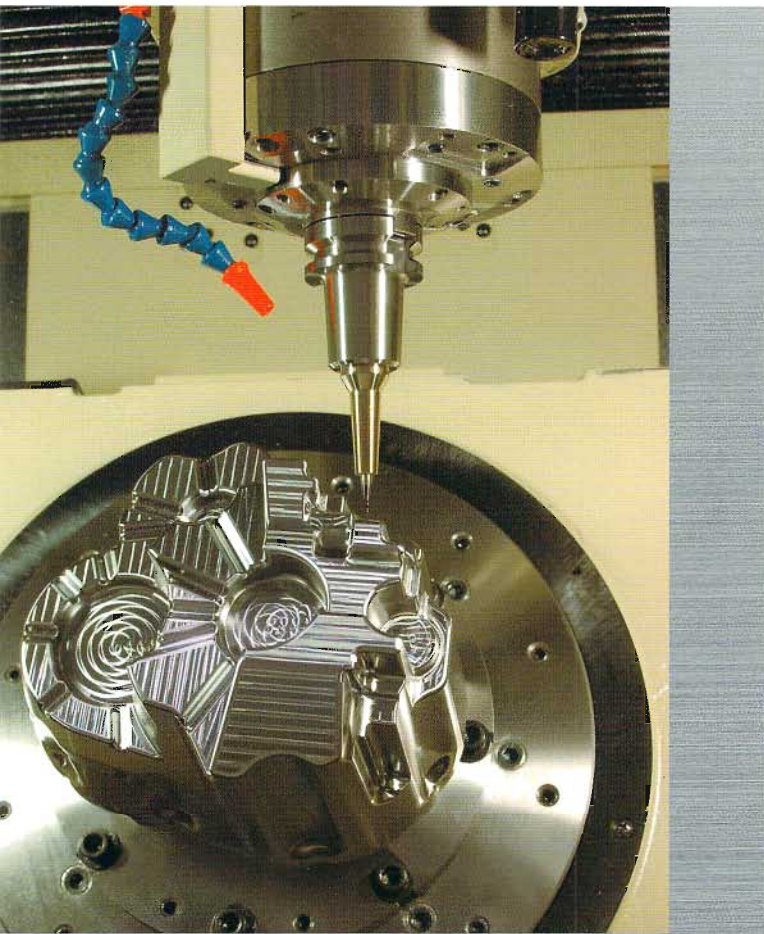

Vertex550-5X



Vertex550

* The photo shows a special specification.

Those with **5X** applies to Vertex550-5X.

Smallest footprint with maximum processing area

The footprint of Vertex is width 2m X depth 3m (standard specification, operation panel is excluded). Regardless of this compact body, workpieces whose size is maximum $\varnothing 500\text{mm} \times \text{height } 325\text{mm}$ (Vertex550-5X) can be loaded.

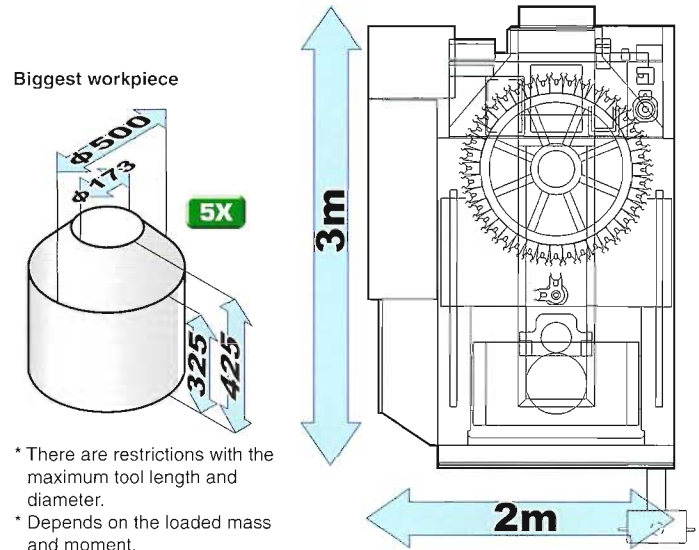

* There are restrictions with the maximum tool length and diameter.

* Depends on the loaded mass and moment.

Infinite capability by giving the table a tilt— a benefit of five-axis processing

5X

Traditional five-axis processing was intended for simultaneous five-axis processing of complex shapes such as impellers, brisks, or turbine blades, and consolidation of processes of multi-surface indexing parts. The point of five-axis processing from now is to process those workpieces that can be processed by three-axis machines. By doing so, the processing time can be reduced and processing quality can be improved.

To collaborate with CAM, Vertex550-5X has functions such as fast data server, tool tip control for AI contour control 2, 5-axis processing, slanted surface processing directives as standard equipment.

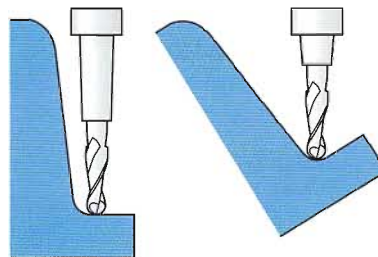

By giving the workpiece a tilt, the tool length can be shortened to realize improvement of processing conditions and quality of the processed surface.



Processing by tool tip control

Usability as well as high speed and high prec

High precision realized by intensive elaboration

The base of Vertex is high precision Intensive elaboration enables jig-borer level geometric precision. In addition, linear scale for straight axes and rotary induct syn for rotating axes (Vertex550-5X) are standard equipment. The positioning accuracy exceeds the standard values by far. In Vertex, high precision as described above and the minimum direction unit and travel unit of 0.1 μm realizes micron-level processing.

Example of circularity by arc interpolation $\varnothing 50\text{mm}$ internal cutting circularity: 1.44 μm

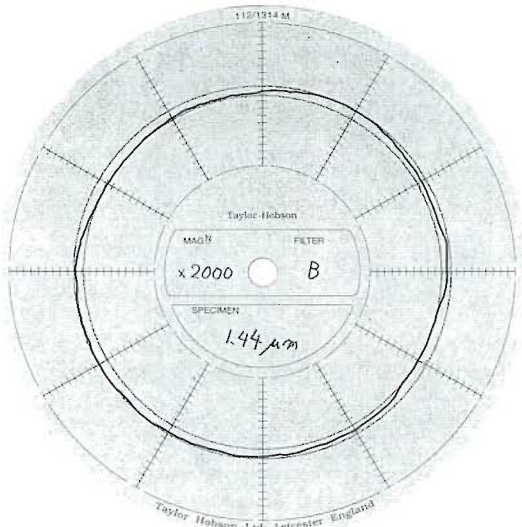

* Reference data. This is not guaranteed.



Example of measured positioning accuracy (X, Y, and Z-axes) >>> POSITIONING ACCURACY <<<

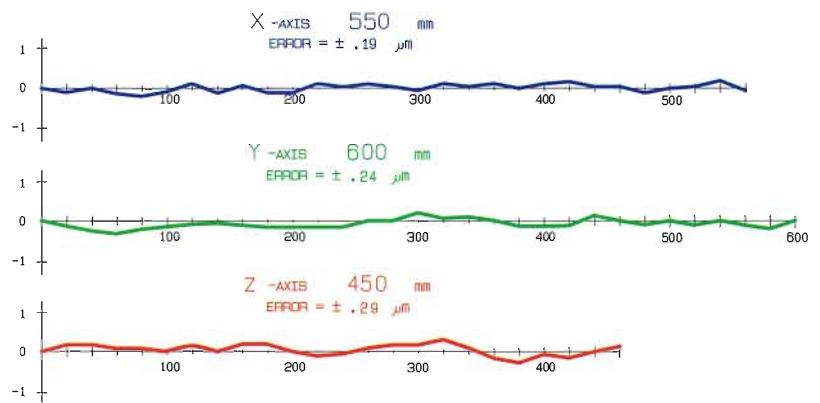

Tilted round table that enables both high speed performance and high precision

5X

Our experiences in horizontal trunnion type five-axis machining centers, which we have delivered many, is used to our tilted round table, which is the core of the five-axis machine. Special gear drives are adopted for A-axis and C-axis. In both fast feed and maximum cutting feed, A-axis: 30 rotations and C-axis: 50 rotations are realized. In addition, full closed loop by rotary induct syn is adopted as standard and the indexing accuracies are A-axis: ± 6 sec. and C-axis: ± 4 sec.

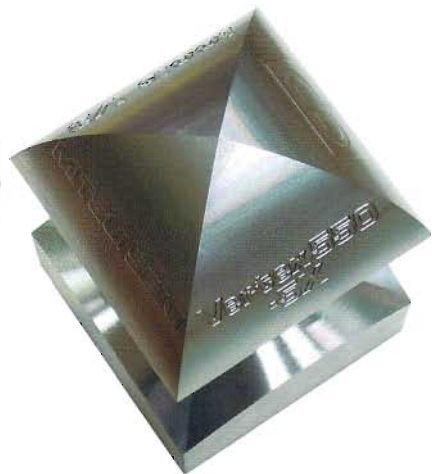
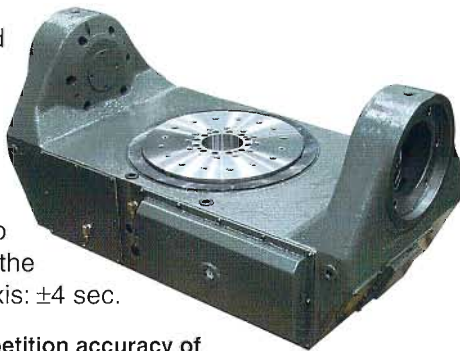

Example measurement of indexing accuracy and repetition accuracy of A and C-axes (of 10 delivered machines)

	Standard value	#1	#2	#3	#4	#5	#6	#7	#8	#9	#10	
Indexing accuracy	A-axis	6	1.4	0.9	0.45	1.0	2.5	0.8	0.7	1.3	2.5	1.2
	C-axis	4	1.2	1.0	1.0	1.5	0.7	0.8	0.7	1.2	0.7	1.0
Repetition accuracy	A-axis	3	0.6	0.5	1.0	0.6	1.0	0.4	0.5	0.7	1.1	0.5
	C-axis	2	0.6	0.5	0.5	0.7	0.3	0.5	0.3	0.7	0.3	0.5

• Example of processed surface where A-axis is indexed by each 90°
 Four edges are exactly aligned to prove high indexing accuracy.

Excellent cutting chip handling

An issue of traditional vertical machining centers, low performance in handling of cutting chips, is solved by the cube on structure.

Cutting chips generated at the cutting point fall on the chip conveyor that is installed right under the table. This conveyor discharges cutting chips quickly to the back of the machine. Because the tank and conveyor can be detached, no space has to be left at the back of the machine for tank maintenance. *

In addition, discharge holes are installed on the left and right side as well as the back. This enables flexible tank layout according to your purpose.

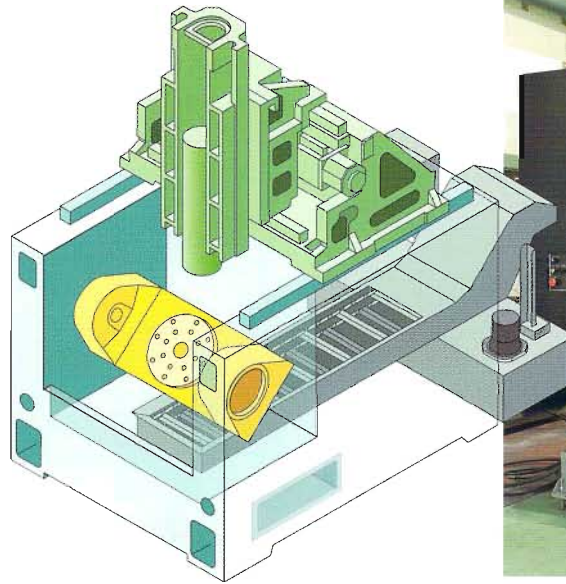

*1500mm is necessary to draw out the chip conveyor.

Design that seeks out operability

Because the table does not move, the operability is extremely good. The height of the table top is 900mm to allow operators to work in non-stressful position.

You can change the tools in the ATC magazine from the doors on the back of the machine. In the case that there is a large tank on the back, a door for tool change is available on the side.



Main operation panel with many rotary switches for intuitive operation.



MOA (Mitsui Operator Aid functions)

Through the soft keys on the right of the LCD display, various aid functions such as checking the origin, list of M codes, and machine switch are available.

Floor Layout Diagram (Standard Specifications)

Common in Vertex550/Vertex550-5X

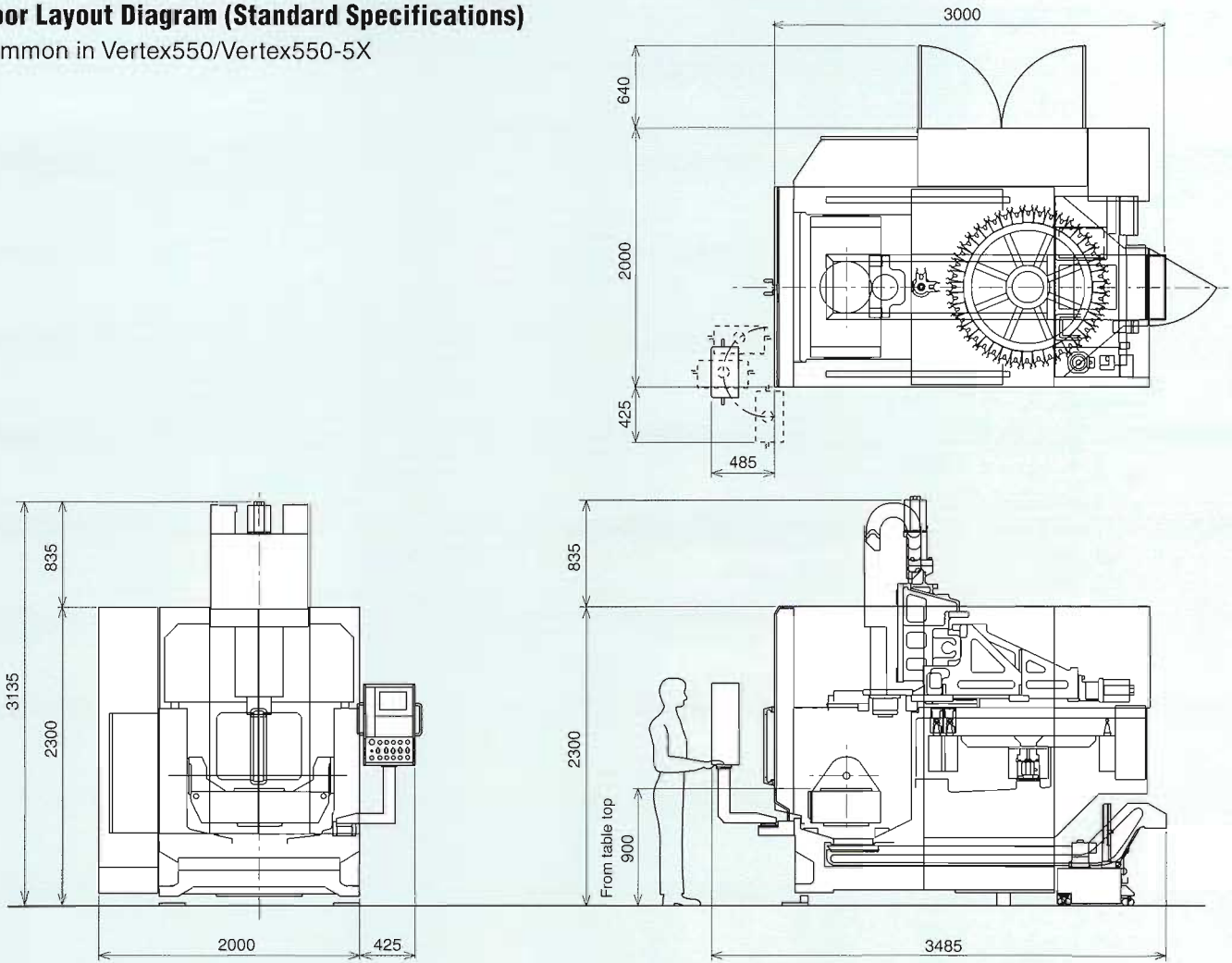

Interference Diagram 5X

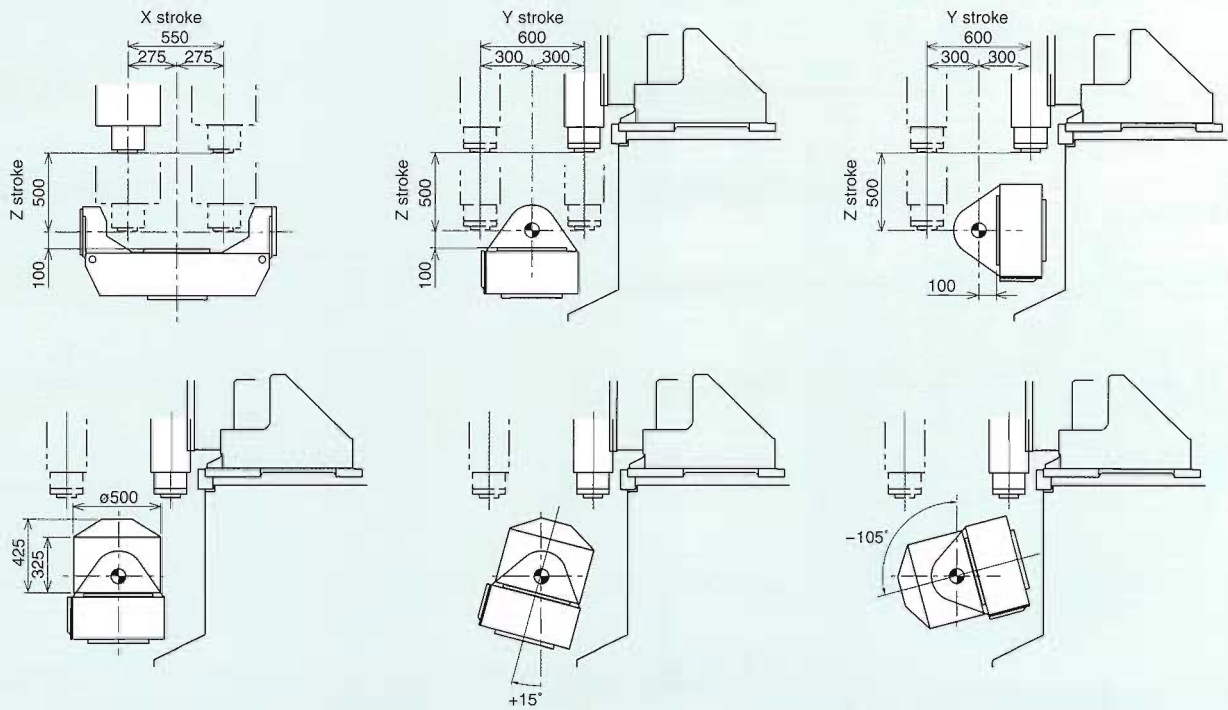

■ Specifications

Item		Unit	Vertex550-5X	Vertex550	
Stroke	X-axis	mm	550		
	Y-axis	mm	600		
	Z-axis	mm	500		
	A-axis	°	+15--105 (every 0.0001°C)	-	
	C-axis	°	360 (every 0.0001°C)	-	
	Distance from the table to the main-axis edge	mm	100~600		
Table	Table size	mm	ø400	700 × 600	
	Maximum processable workpiece (diameter x height)		ø500 × 325	-	
	Maximum load weight	kg	350 (When the A-axis is horizontal)	800	
	Moment load	N-m	200	-	
	Shape of the top surface		28-M12 (PCD150 & 250 & 350)	Five T-trails (trails width 18 mm)	
	Distance from the flolor to the top surface	mm	900		
Main axis	Main axis rotation speed	min ⁻¹	[Select 25,000 or 15,000 for the main axis]		
	Taper		ISO 7/24 Taper No. 40 (OP: HSK-A63)		
	Main-axis motor output	kW	18.5/15 (25,000) or 7.5/5.5 (15,000)		
	Maximum torque (25% ED / continuous)	N-m	28.6/14 (25,000) or 65/44 (15,000)		
	Main axis diameter	mm	ø65		
Feed rate	Fast feed rate	XYZ-axes	mm/min		
		AC-axes	min ⁻¹		
	Cutting feed rate	XYZ-axes	mm/min		
		AC-axes	min ⁻¹		
	Minimum direction unit	XYZ-axes	mm		
	Minimum travel unit	AC-axes	°		
Position detection	XYZ-axes		Absolute linear scale		
	AC-axes		Absolute induct syn		
ATC	Number of storable tools		40	24 (OP: 40)	
	Maximum tool length	mm	300		
	Maximum tool diameter	with adjacent tool	mm	ø90	
		without adjacent tool	mm	ø125 (full circle)	
	Maximum tool weight	kgf	10		
Tool selection method		Random, hole address specification			
NC device			FANUC 31i-A5	FANUC 31i-A	
Accuracy	Positioning accuracy	XYZ-axes	mm		
		AC-axes	sec		
	Repetition accuracy	XYZ-axes	mm		
		AC-axes	sec		
Power supply, air	Power consumption		50kVA		
	Required air		Pressure 0.4 MPa or more, feed rate 1200 NI/min or more		
Machine size	Footprint (standard specifications)	mm	Width 2,050 × depth 3,485 × height 3,113		
	Shipment size	mm	Width 2,050 × depth 3,485 × height 2,800		
	Machine weight	kg	About 9,500	About 8,800	

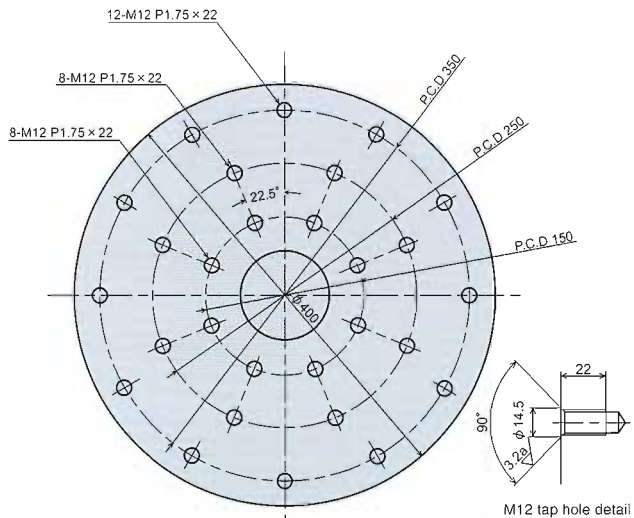

Vertex550-5X Table Top Diagram

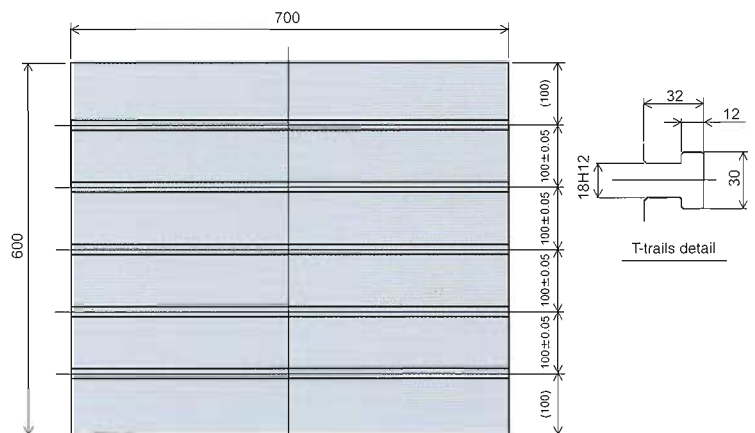

Vertex550 Table Top Diagram

■ Standard Specifications (Machine)

Entire cover	Chip conveyer (scraper method x 1)	Manual pulse generator (with emergency stop button)
Operator door and ATC magazine door, power lock	Automatic power shut-off device	MOA functions (Mitsui Operator Aid functions)
Main-axis cooler (inverter control)	Operation light (LED light is installed on the edge of the main axis)	Main axis heat change correction function (with sensor)
Cutting oil device (200L tank and pump)	Signal tower (with three lights)	Installation basic parts

■ Standard Specifications (NC) FANUC31i-A/31i-A5

10.4 " color LCD	Macro executor + C language executor	Self diagnosis function
AI contour control	Reader/puncher interface	Auto speed change
Absolute/incremental directions	Rigid type	Manual return to the reference point
Exact stop (G09)	Return to the reference point (G28, G29)	Decimal point input / calculator type decimal point input
Optional block skip	Workpiece coordinate system (G54~G59)	Cutting feed rate clamp
Optional block skip add (Screen SW)	Workpiece coordinate preset (G92.1)	Bell-shape cutting feed change after interpolation
Custom soft capacity 2MB	One-direction positioning	straight-shape cutting feed change after interpolation
Custom macro	Operation hours and number of parts display	Tangent speed constant control
Custom macro common variable add	External data input	Bell-shape acceleration before advance read correction
Sequence number search	Extended program edit	Built-in Ethernet
Stored stroke check 2	Tool diameter and blade tip correction (G40, G41, G42)	Operation history display
Programmable data input	Tool correction memory C	Bell-shape fast feed change after interpolation
Programmable parameter input	Number of correctable tools 99	Return to third/fourth reference point
Graphic functions	High speed HRV3 function	Aid function lock
Background edit	High speed skip	Every-minute feed (G94)
Program memory 128KB (320m)	Coordinate rotation	Number of registered program extension
Helical interpolation	Clock function	Number of axes simultaneously controlled extension

Additional functions of Vertex550-5X (FANUC31i-A5)

AI contour control II	Fast data server function (with 128 MB card)	Tool position offset
Tool tip control for five-axis processing	Program memory 2 MB (5120m)	Detachable control axis
Tilted surface processing direction	Processing condition selection function	

■ Machine Options

Two surface bond main axis	HSK-A63 specifications	Center through oil feed device	Outlet pressure 1MPa	Automatic fire extinguisher interface
	BigPlus specifications		Outlet pressure 3MPa	Automatic measurement correction device (ACS-7S/7H)
Pull stat bolt	JIS type support	Mist collector		Tool length and diameter measure (AMCS-7-T)
	MAS I type support	Chip bucket		Tool damage detection device
	MAS II type support	Splash gun		Automatic tool length measurement and tool damage detection (ATLS)
40 ATC (Standard with Vtx550-5X)		Air gun		Tool information configuration function
Chip conveyer with drum filter		Weekly timer		Automatic tool check before processing
Oil skimmer		Operation counter		Tool life reset function
Air blow device (external nozzle type)		Ground-fault circuit interrupter		Processing priority function (scheduling function)
Large capacity coolant tank (installed on the machine side)		RS232C interface		Load monitor
Cutting oil cooler		100V 3A outlet		

■ NC Options FANUC31i-A/31i-A5

*: Standard Specifications Vertex550-5X

Inch/metric switch	Program memory	256KB (640m)	Number of workpiece coordinate system	48 pairs
Involute interpolation		512KB (1280m)		300 pairs
Polar coordinate interpolation		1MB (2560m)		Three-dimensional coordinate conversion
Cylindrical interpolation		2MB (5120m)*		Program restart
Helical interpolation		4MB (10240m)		Manual handle interrupt
Nano smoothing		8MB (20480m)		Chamfering at any angle, corner R
Convolute/cone interpolation		Processing function selection function *		Programmable mirror image
NURBS interpolation		Fast data server function (with 128 MB card)*		Polar coordinate direction
Smooth interpolation		1 MB memory card for data server		Playback
Three-dimensional arch interpolation		Fast Ethernet function		Scaling
F1 digit feed		High speed serial bus		Drawing copy
Automatic corner override		FOCAS 2		Retrace
Inverse time feed	Number of tool correction	200 pieces		Pattern data input
AI contour control II *		400 pieces		F15 tape format
High speed processing		499 pieces		Workpiece placement error correction function
Number of advance read blocks extension (maximum 1000)		999 pieces		Cs contour control function
Jerk control		2000 pieces		Interrupt type custom macro
Number of registered programs extension 2		Tool position offset *		Tool life management function (maximum 256 pairs)
Sequence number reference stop		Three-dimensional tool correction		Number of pairs of tool life management function add (maximum 1024 pairs)
Background drawing		Rotary table dynamic fixture offset		



All the specifications indicated in the brochure are subject to change without prior notice.

 **MITSUMI SEIKI KOGYO CO.,LTD.**

SPHERE TOWER TENNOZ
2-2-8, HIGASHI-SHINAGAWA, SHINAGAWA-KU, TOKYO, 140-0002 JAPAN
TEL: +81-3-5715-4022 FAX: +81-3-5715-3919
URL: <http://www.mitsuseiki.co.jp>

ДЖАПАН ТУЛ СЕРВИС,ЛТД
представительство в москве



Россия ,119049 Москва
Коровий вал д7, под 6. кв 168
Тел./факс : (495) 970-15-73
<http://www.jtools.biz>
e-mail : info@jtools.biz
<http://www.japantool.ru>